

Rbee Solar User Guide

Putting single-phase and three-phase meters into service
UK

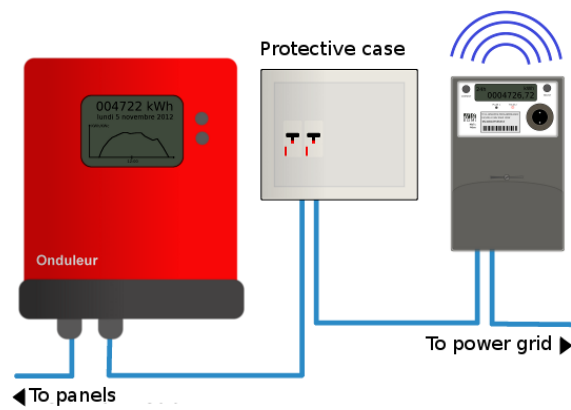

Revision	Description	Date
1.0	Creation of the UK document	01/05/11
1.1	Update contact details	17/07/14

Introduction

The Rbee Solar production monitoring system consists of communicating meters and a web consultation and parameterization application. This document describes the installation of the meters and the verification of proper operation.

If you have a problem, you can contact Rtone Support (France) or your distributor:

support@rtone.fr or on **+33 4 78 47 70 78** (8.00 - 12.00 and 14.00 - 18.00)

Once connected, the meters store the metering data (Wh) in their internal memory at 10 minute intervals. The data is transmitted to the Rbee Solar servers twice a day between 00.00 and 02.00 and 12.00 and 14.00 (GMT). Once the meter has been installed, you must parameterize the installation in the web application by connecting to your portal. When the meter connects for the first time, it will transmit the data for the last 48 hours and its GPRS subscription will begin on that date.

INFORMATION

Consult the web portal documentation for more information:

help.pvmeter.com

Putting Rbee Solar meters (Mk7C and Mk10) into service

The Mk7C meter is a direct-connection single-phase meter with a capacity of 100 A.

The Mk10 meter is available in two models, the first one for direct connection up to 100 A (Mk10-WC) and the second one to connect one or more CTs (Mk10-CT). The Mk10-WC can therefore be used to monitor the production of a three-phase installation of maximum output 70 kWc. The Mk10-CT meter operates with Current Transformers (CTs). The setting of the transformation ratio and of the number of CTs must be carried out before delivery or remotely by contacting Support (GSM/GPRS connection).

GSM/GPRS communications

Communications with the Rbee Solar servers are via the internal GSM/GPRS modem. The meter must therefore be in a location covered by a mobile network. The Rbee Solar offering is in partnership with SFR and permits operation throughout Europe. The SIM card will connect to the best mobile (GPRS) network available.

The SIM card is factory pre-installed in the meter's modem

All the SIM cards and the subscriptions are managed by Rtone, so you do not have to concern yourself with their administration. In addition, a 2-year subscription is included in the hardware offering.

Should your installation location not be covered by a mobile network, please contact Rtone Technical Support.

It is advisable therefore to verify before installation whether coverage is available.





Caution

Do not forget to reconnect the modem's RJ45 cable at the time of installation.

When the meter **has been installed and supplied with power**, you will have the possibility of verifying the reception level on the LCD screen. Press the screen's right-scroll button (select) several times to display the GSM signal strength (to the left of the screen).

Interpretation of the reception level:

> 15	Good	
10 to 15	OK	
5 to 10	Poor	
< 5 or 99	Do not install	

If your signal is **less than 5 or equal to 99**, it is dangerous or even impossible to install the meter. You must then check whether the mobile network is stronger or available in the vicinity of the meter's current location. In this case, you can connect an antenna with a cable extension in order to move away from the place which has poor reception. If you do not have this antenna, contact your distributor.

CAUTION

When the meters are not supplied with power, the GSM modem is cut off and the meter will always display 99.

External antennas



Electrical installation

The meter must be positioned after the inverter's AC protective case. You must comply with the standards in force for the installation of electrical equipment.

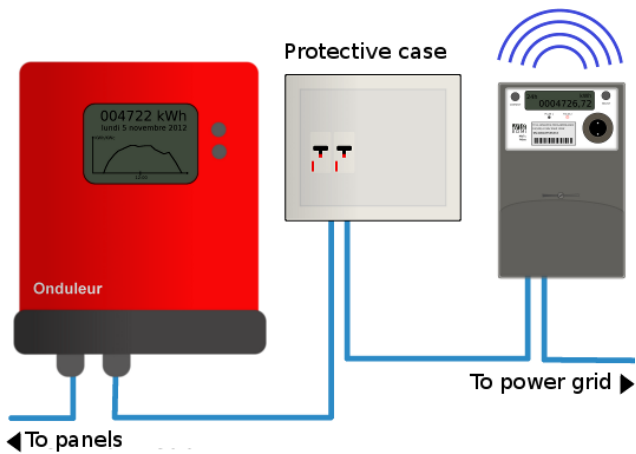

The meter can be installed on the wall or on an electrical panel or inside a case.

Mk7C wiring

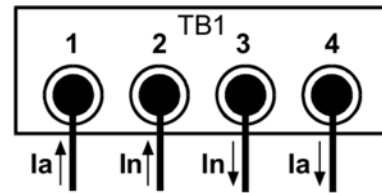

Connect the inverter's output to the meter's input (TB1). Phase must be connected to terminal 1, neutral to 2. Then connect the Mk7C meter's output to the power grid. Terminal 3 is neutral, 4 is phase.

When the meter is correctly supplied with power, the LCD screen comes on. Be sure to plug the GSM/GPRS modem's RJ45 jack into the meter's RJ45 port.

Mk10-WC wiring

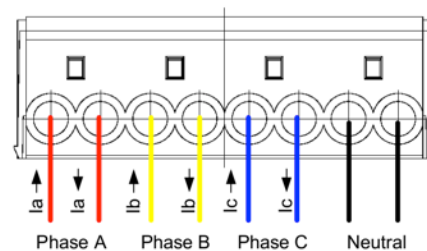
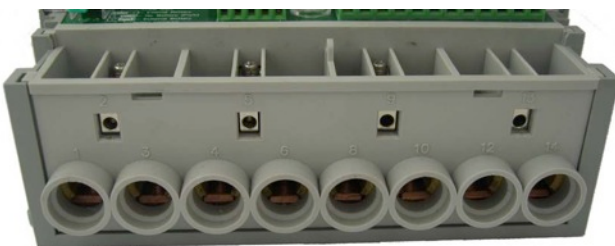

In the case of direct three-phase connection (up to 100 A), you must connect the 3 phases and the neutral respectively to the following terminals:

Phase	Input (inverter)	Output
Phase 1	1	3
Phase 2	4	6
Phase 3	8	10
Neutral	12	14

When the meter is correctly supplied with power, the LCD screen comes on. Be sure to plug the GSM/GPRS modem's RJ45 jack into the meter's RJ45 port.

Mk10-CT wiring

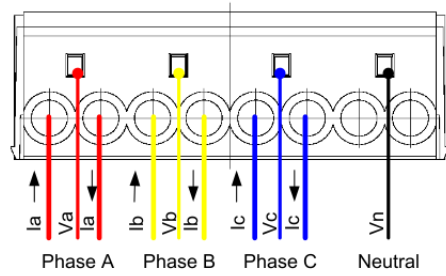

For an installation > 70 kWc, you must use Current Transformers (CTs) to measure the current. The transformation ratio must be specified with the order. You must then connect each CT on the Phase A, B and C inputs and finally supply the meter with power by connecting the phases and neutral on the Va, Vb, Vc and Vn inputs.

CAUTION

Comply with phase order and coherence between Va,b,c and Ia,b,c. Reversal would result in a totally incorrect measurement.

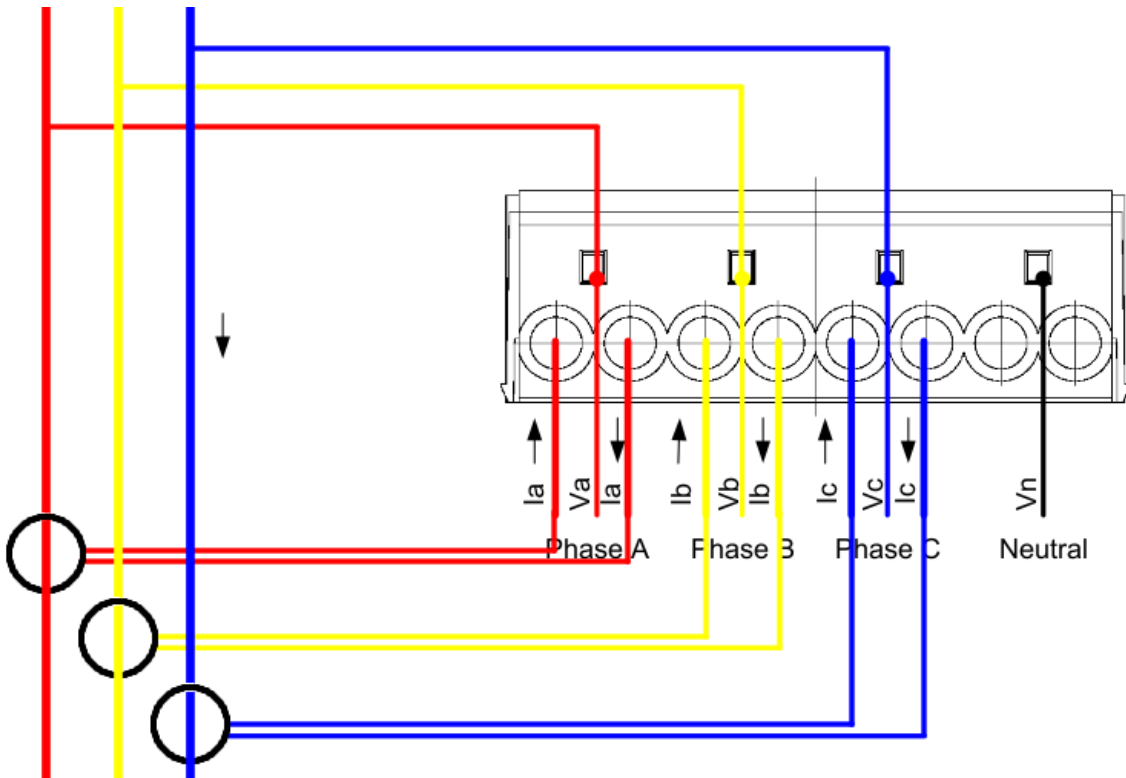

Phase	Input	Output
Phase 1 (TI - Ia)	1	3
Phase 2 (TI - Ib)	4	6
Phase 3 (TI - Ic)	8	10
V1	2	
V2	5	
V3	9	
Neutral	13	

Value of metering and accuracy

Rbee Solar single-phase and three-phase meters are MID approved and have a class 1 accuracy (1%) necessary to green certificate metering.

INFORMATION

Because of the MID European certification of Rbee Solar meters, the metering data has legal value and complies with the accuracy levels in force for energy invoicing.